

Quote in millimetri

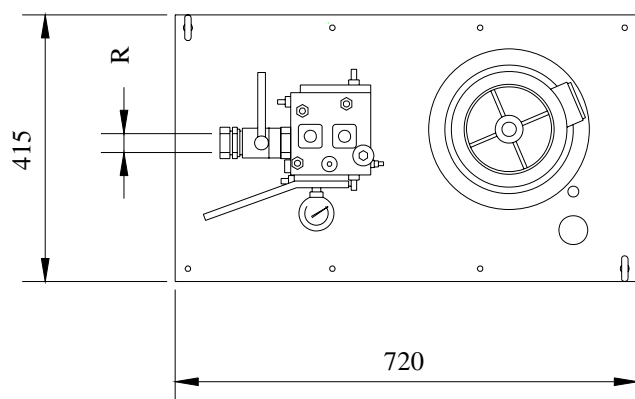

Attacco olio diritto

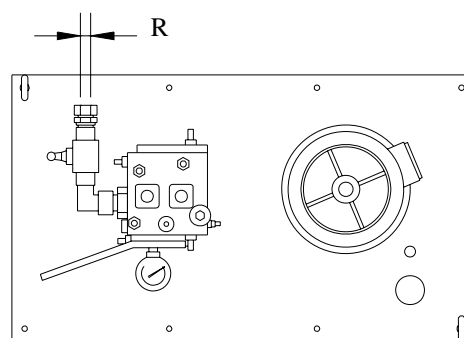

Attacco olio 90°

Tipo Serbatoio	Tipo Pompa [l/min]	Raccordo [mm - Gas]	CAPACITA' [litri]		Peso [kg]
		R	Livello Min.	Disponibile	
01	8, 12	22 -G 3/8 -G 1/2 -G 3/4	30	40	60
	8, 12, 16 PROL	22 -G 3/8 -G 1/2 -G 3/4	17	53	
	25, 30, 35	22 -28 -G 3/4 -G1"	17	53	

**DIMENSIONI
CENTRALINE
01/E**



Start Elevator

06 211 / I

rev. 3

1/2

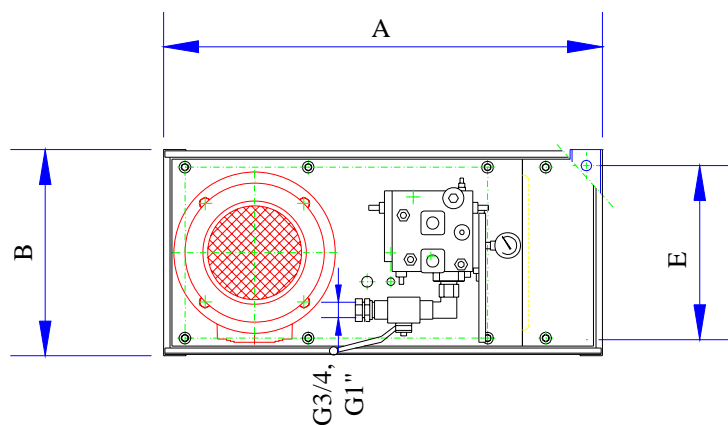
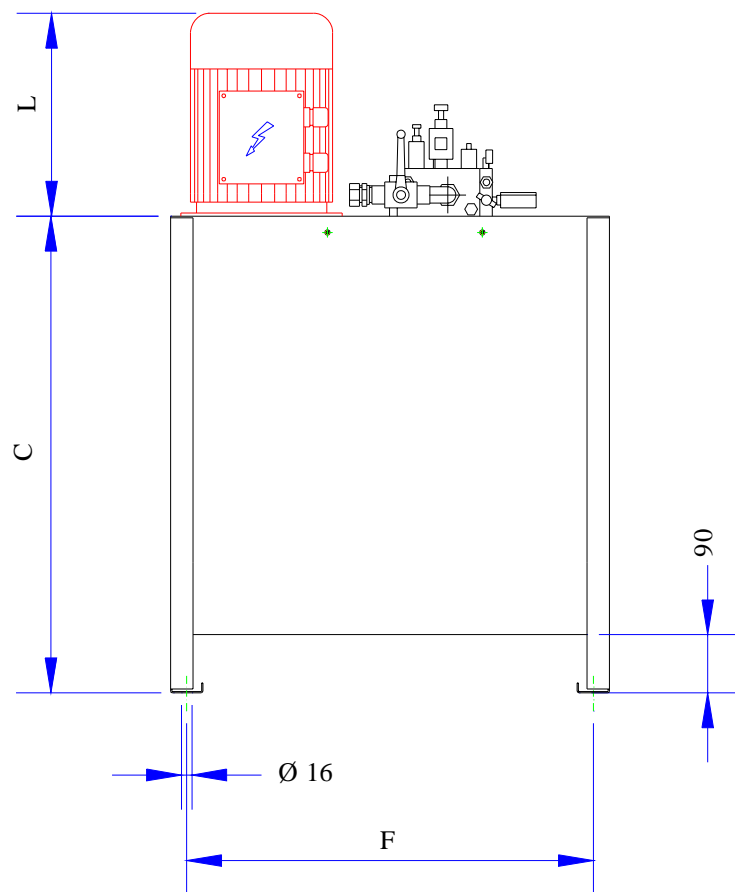

Quote in mm

Tipo Serbatoio	Tipo Pompa [l/min]	DIMENSIONI [mm]						CAPACITA' [litri]		Peso [Kg]
		A	B	C	E	F	L	Level. Min.	Disponibile	
01SLAH	30-55 L/1'	680	320	615	270	630	300	25	66	75
01SLA	30-55 L/1'	680	320	775	270	630	300	25	100	80

**DIMENSIONI
CENTRALINE
01/E - SLA**



Start Elevator

06 211 / 1

rev. 3

2/2